



**PERFORMANCE DATA SHEET
NEMA PREMIUM NR CAN NEMA 12 - 12**

Catalogue #: MQP-98

HP	kW	Voltage	S.F. @ 60Hz	EFF.	P.F.	Frame	Design	L.R. Amps
200	149,20	460	1,15	95,8%	0,82	449T	B	1450

60 Hz								Code	F.L. RPM
208	230	416	460	480	575	600			
/	/	/	238,00	/	/			G	1185

50 Hz								
FLA			S.F. @ 50Hz	Efficiency	Power Factor	Code	F.L. RPM	
190	380	415						
/	290		1,00	94,1%	0,840	E	985	

Wgt. Lbs	PH	Duty	Insul. Class	Amb.	Elevation	Temp. Rise° C
3100	3	Cont.	F	40°C	1000M (3,300 Ft)	< 80

% Efficiency		% Power Factor		Torque		Winding Resist. Ω	Safe Cold Start (Secs)
Full Load:	95,8%	Full Load:	0,82	Full Load Ft/Lbs	886,4		
3/4 Load:	95,6%	3/4 Load:	0,79	Locked Rotor %	140		
1/2 Load:	95,0%	1/2 Load:	0,71	Break Down %	245	0	20

Rotor Inertia Wk2 Lb-Ft2	Max Load Inertia Wk2 Lb-Ft2	Shaft Material	Frame Material	DE Bracket Type	ODE Bracket Type	Enclosure	NEMA Rating	Lead Wire Size
142,38	2900	1045	Cast Iron	Cast Iron	Cast Iron	TEFC	IP55	3AWG

Ball Bearings		Grease	Mount Type	Orientation	Paint	Sound Pressure @ 3FT	Sound Power
DE	ODE						
NU319	6318	Mobil PolyrexEm	Rigid	Horizontal	RAL6022	88	100

Inverter Duty, Motor meets MG1 parts 31.4.4.2	VFD SF	Constant Torque Range	Variable Torque Range	Constant HP RPM
	1,00	10:1	20:1	1800

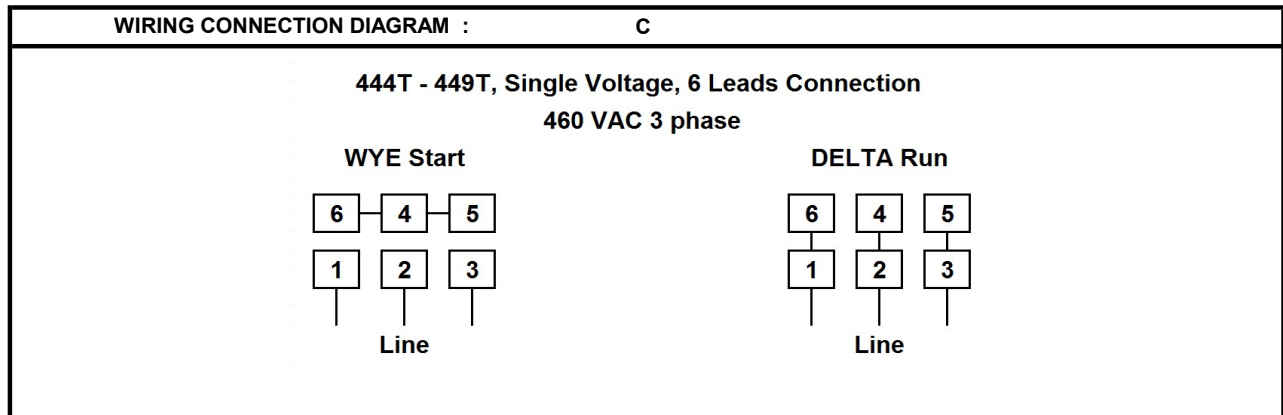

Date: 2023-12-13
 Customer: _____
 Contact: _____
 Submittee: J.C. Lavallée

Catalogue #: MQP-98

NEMA PREMIUM NR CAN NEMA 12 - 12										
HP	VAC	RPM	Enclosure	Frame	Frequency	Design	Poles	LR Code Letter	Insulation Class	Temp. Rise °C
200	460	1185	TEFC	449T	60 Hz	B	6	G	F	< 80
	0Hz	6Hz	15Hz	30Hz	45Hz	60 Hz	75Hz	90Hz	105Hz	120Hz
Amps	238	238	238	238	238	238	238	238	238	238
RPM	0	118,5	296,25	592,5	888,75	1185	1481,25	1777,5	2073,75	2370
Torq ft.lb	709,13	709,13	886,41	886,41	886,41	886,41	709,13	590,94	506,52	443,21
Peak Tq ft.lb	986,14	1972,27	1972,27	1972,27	1972,27	1972,27	1577,82	1314,85	1127,01	986,14
HP	0	16,0	50,0	100,0	150,0	200,0	200,0	200,0	200,0	200,0
	Locked Rotor	Pull-Up	Breakdown	Rated Load	Idle	Duty	S. F.	Ambient	Elevation	dBA @ 1M
Speed (RPM)	0,0	504	960	1185	1200	Continuous	1,15	40°C	3,300 ft	88
Current (Amps)	1450,0	1232,5	862,8	238,0	90,4	VFD Rating: Meets MG1 parts 31.4.4.2				
Torque (ft-lbs)	1241,0	930,7	2171,7	886,4	0,0	C.T.	10:1	V.T.	20:1	VFD SF 1.00

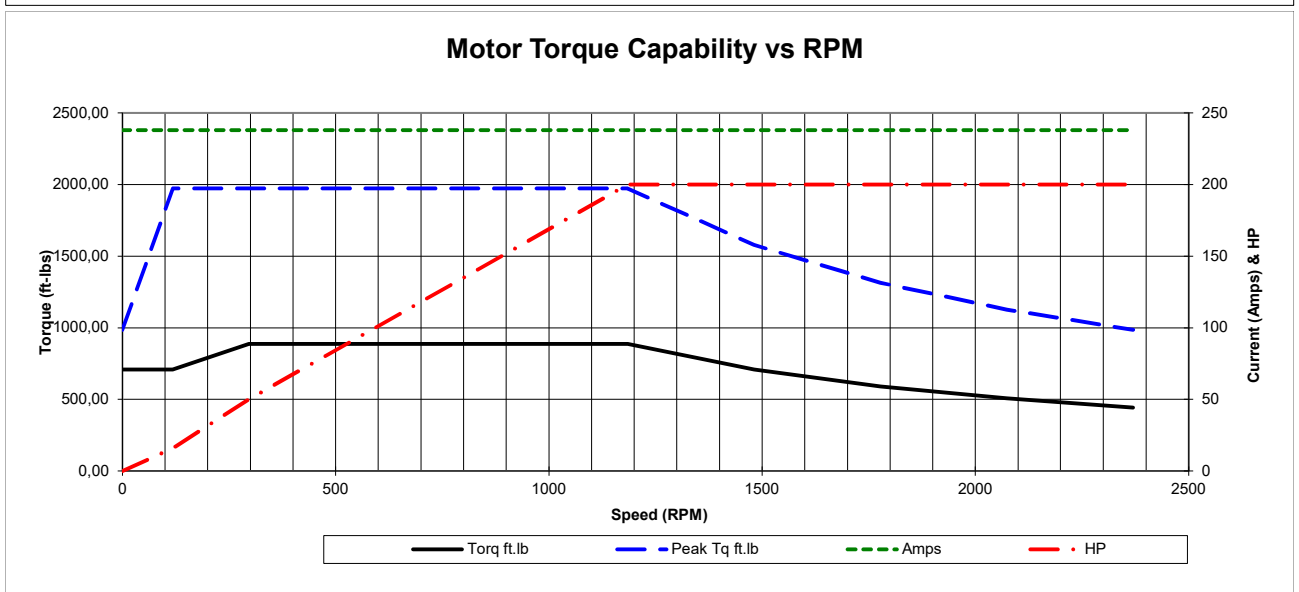
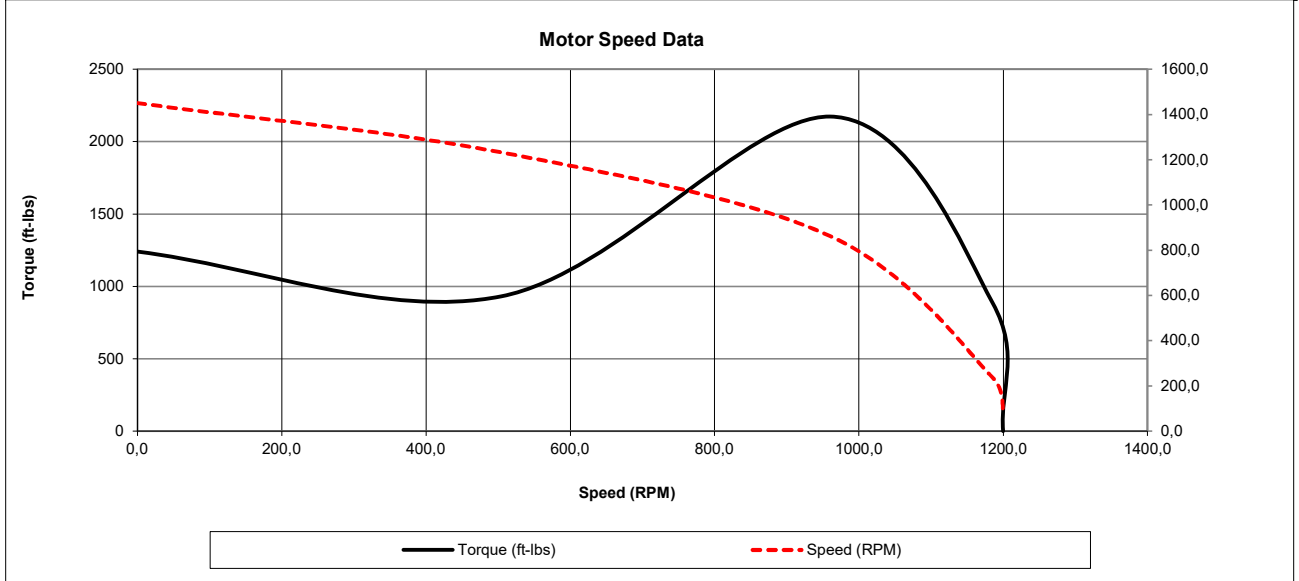



Date: 2023-12-13
 Customer: _____
 Contact: _____
 Submittee: J.C. Lavallée

Catalogue #: MQP-98

NEMA PREMIUM NR CAN NEMA 12 - 12										
HP	VAC	RPM	Enclosure	Frame	Frequency	Design	Poles	LR Code Letter	Insulation Class	Temp. Rise °C
200	460	1185	TEFC	449T	60 Hz	B	6	G	F	< 80
Load %	0%	25%	50%	75%	100%	125%	150%			
Amps	90,44	78,54	140,90	185,88	238,00	299,75	368,41			
Torq ft/lbs	0	219,52	440,42	662,71	886,41	1111,53	1338,09			
RPM	0	1196,25	1192,5	1188,75	1185	1181,25	1177,5			
Eff	0	94,62	95,00	95,60	95,80	94,29	93,92			
PF	0	63	71	79	82	82,82	81,18			
	Locked Rotor	Pull-Up	Breakdown	Rated Load	Idle	Duty	S. F.	Ambient	Elevation	dBa @ 1M
Speed (RPM)	0	504	960	1185	1200	Continuous	1,15	40°C	3,300 ft	88
Current (Amps)	1450	1232,5	862,8	238	90,44	VFD Rating: Meets MG1 parts 31.4.4.2				
Torque (ft-lbs)	1240,98	930,73	2171,71	886,41	0,0	C.T.	10:1	V.T.	20:1	VFD SF 1.00

